

Verbindungstechnik – LWL

[Network Connectivity - FO]

LWL-Kassette SC – Spleißversion – OM4 [FO cassette SC – splice version – OM4]

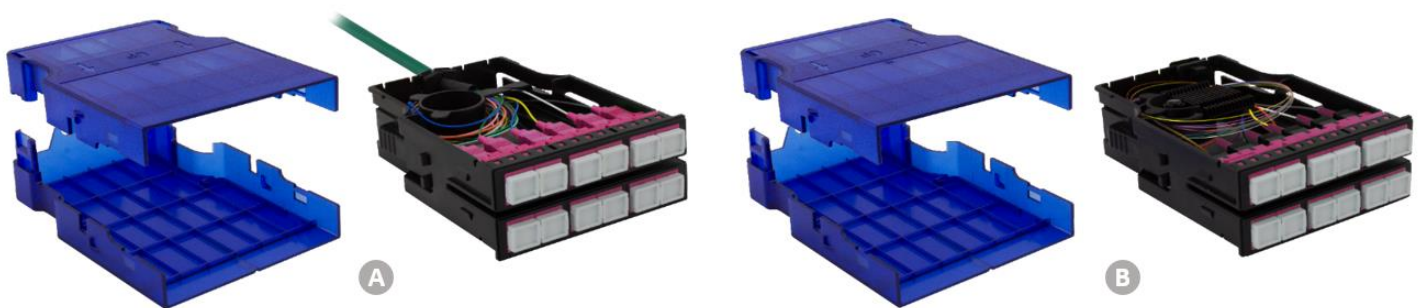

Die modularen LWL-Kassetten als Spleißversion von TKM sind direkt geeignet für die Verwendung in Glasfasernetzen. Dabei können sie individuell an schon verlegten Installationskabeln angespleißt, oder in Kombination mit einseitig vorkonfektionierten Kassetten verwendet werden. Speziell in Rechenzentrumsanwendungen ist die modulare Nutzung von gemischten LC, SC und RJ45 Ports in einem Chassis von großer Bedeutung. Die modularen Kassetten haben folgende Haupteigenschaften:

- Plug & Play – werkzeuglose Installation im 19“ Chassis
- Kapazität: bis zu 12 Fasern pro Kassette
- Mischbar mit modularen Kupferkassetten im selben Chassis
- Verfügbare Kassettensversionen: a) einseitig vorkonfektioniert b) spleißfertig

[The modular FO cassettes as the splice version of TKM are direct applicable to use in FO networks. The splice cassettes can be individually spliced to already existing horizontal cables or used in combination with single sided pre-terminated cassettes. Especially in data center applications the modular usage of LC, SC and RJ45 ports in one chassis is highly relevant. The modular cassettes have the following main characteristics:

- *plug & play – toolless installation in 19inch chassis*
- *capacity: up to 12 fibres per cassette*
- *mixable with copper cassette in the same chassis*
- *available cassette versions: a) singled sided pre-terminated b) ready to splice]*

Eigenschaften Kassette [characteristics cassette]

Spezifikation Kassette [specification cassette]	
Gemäß Standard [acc. to specification]	IEC 60793-2-10
Material Gehäuse [material housing]	PC - Polycarbonate
Material Verriegelung [material release lug]	PP - Polypropylen
Optische Eigenschaften Kupplung [optical characteristics adapter]	
Kupplungstyp [type of adapter]	SCdx
Material Kupplung [material adapter]	PEI - Polyetherimid
Material Ferrule [material ferrule]	Keramik [ceramic]
Farbe Kupplung [colour adapter]	Erikaviolett - ähnlich RAL 4003 [heather violet - similar RAL 4003]
Steckzyklen [mating cycles]	> 750

Zeichnung [drawing]

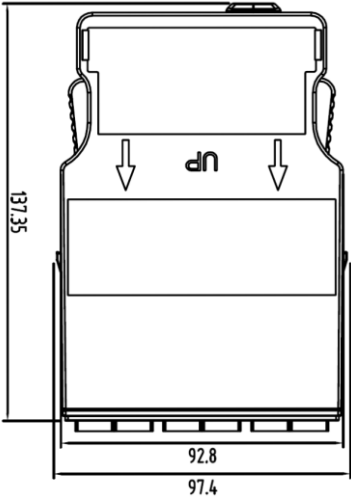
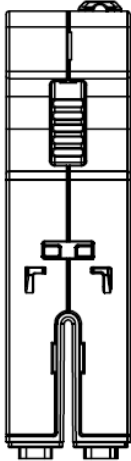
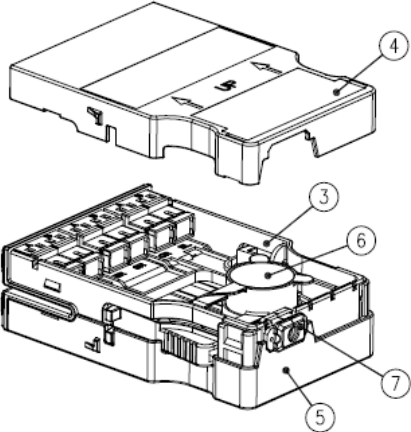
			
1	LWL Kupplung A [FO adapter A]		
2	LWL Kupplung B [FO adapter B]		
3	Kassettenmittelteil [middle part of cassette]		
4	Kassettenoberteil [top part of cassette]		
5	Kassettenunterteil [bottom part of cassette]		
6	Faserspule [fibre spool]		
7	Gummierelement für Kabeleinführung mit Zugentlastung [rubber element with cable entry and strain relief]		

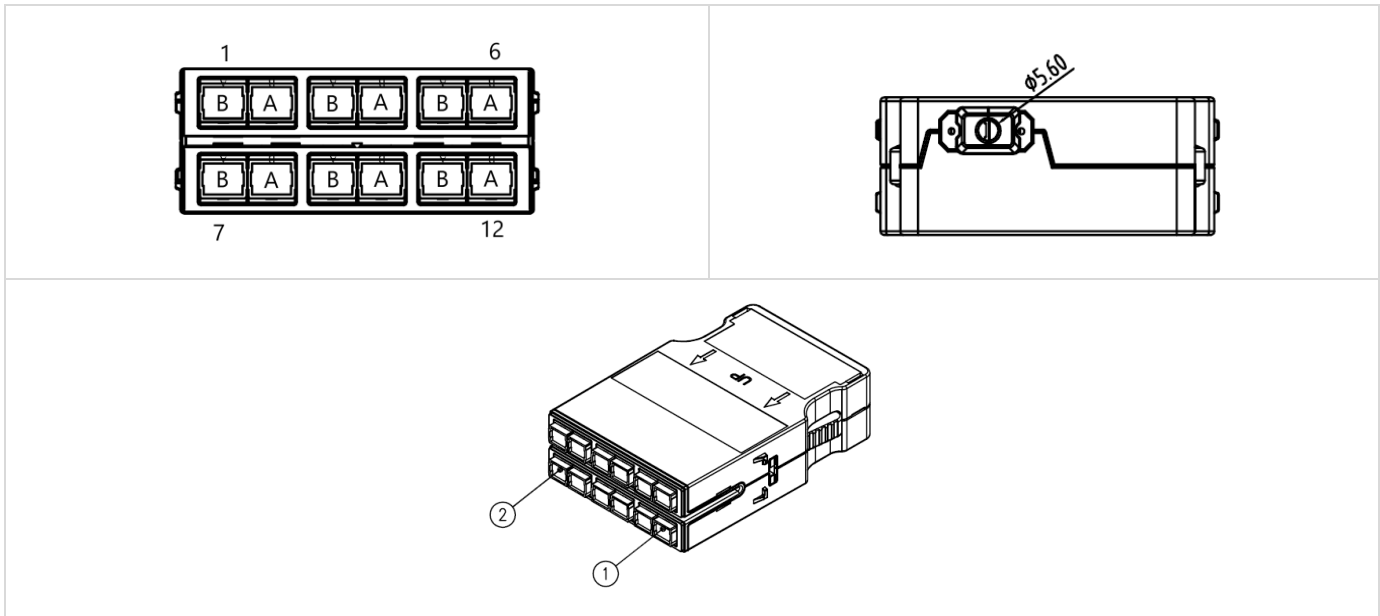

Eigenschaften Minibreakout Indoorkabel I-V(ZN)H [characteristics minibreakout indoor cable I-V(ZN)H]

Kabelaufbau [cable construction]

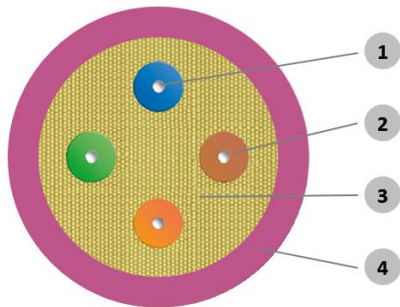

*exemplarisch mit 4 Fasern
[exemplarily with 4 fibres]

1	Glasfasern [fibres]
2	Semilose Vollader [semi loose tube]
3	Glasarmierung [glass armour]
4	Außenmantel FRNC/LSZH [outer jacket FRNC/LSZH]

Anwendung [application]	Vorkonfiguriertes modulare Kassette zur Anwendung in bspw. einem Rechenzentrumsnetzwerk, einer Etagen- oder Gebäudeverkabelung [pre-terminated modular cassette for the application in e.g. data center networks, floor or enterprise network]
Farbe Außenmantel [colour outer jacket]	Erikaviolett [heather violet]
Typ Ader: [type of fibre]	Semilose Vollader [semi-tight buffered fibre]
Außendurchmesser [mm] [outer diameter [mm]]	0,9
Farbcode der Adern [colour code of fibres]	blau, orange, grün, braun, grau, weiß, rot, schwarz, gelb, violett, rosa, türkis [blue, orange, green, brown, grey, white, red, black, yellow, violet, pink, turquoise]
Min. Biegeradius nach IEC 60794-1-2 E11A in XX x Außendurchmesser [min bending radius acc. to IEC 60794-1-2 E11A in XX x outer diameter]	
Fest verlegt (statisch)	10
Während Montage (dynamisch)	15

Spezifikation: Faser
[specification: fibre]

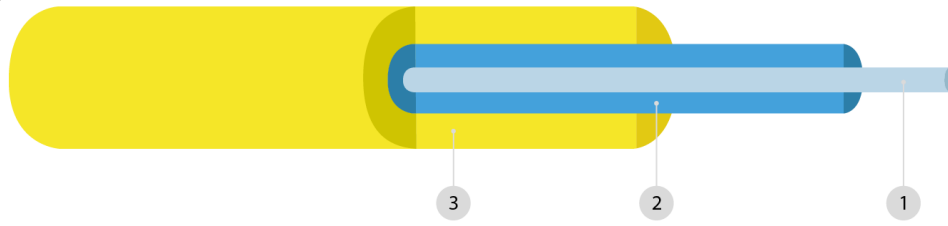

*exemplarische Abbildung, Produkt kann farblich abweichen
[exemplary picture, product may vary in colour]

1 Kern [core]		2 Ummantelung [cladding]			3 Beschichtung [coating]		
Fasertyp [type of fibre]		Multimode Faser, biegeunempfindlich, G50/125, OM4 [multimode fibre, bend optimised, G50/125, OM4]					
Faserspezifikation [fibre specification]		ITU-T G.651.1, IEC 60793-2-10 type A1a.3b					
Übertragungseigenschaften [transmission characteristics]		Messwerte Produkt [measurement value of product]			Normwerte [measurement value of standard]		
Wellenlänge [nm] [wave length [nm]]		850	953	1300	850	953	1300
Dämpfung maximal (unkabelt) [db/km] [attenuation maximum (uncabled) [db/km]]		2,30	n.a.	0,60	n.a. [n.a.]	n.a. [n.a.]	n.a. [n.a.]
Dämpfung maximal verkabelt [db/km] [attenuation maximum (cabled) [db/km]]		2,5	n.a.	0,7	3,5	1,5	3,5
OFL-Bandbreite [MHz x km] [OFL bandwidth [MHz x km]] TIA/EIA 455-204 // IEC 60793-1-41		3500	n.a.	500	3500	500	3500
High-Performance EMB-Bandbreite [MHz x km] [high-Performance EMB bandwidth [MHz x km]] TIA/EIA 455-220A // IEC 60793-1-49		4700	n.a.	n.a. [n.a.]	4700	n.a. [n.a.]	4700
Brechzahlindex [refractive index]		1,483	n.a. [n.a.]	1,478	n.a. [n.a.]		
Biegeeigenschaften [macro bending characteristics]		Anzahl Windungen [numbre of windings]			Max. induzierte Biegedämpfung [dB] [max. induced attenuation [dB]]		
					@850nm	@1300nm	
Biegeradius R=37,5mm [bending radius R=37.5mm]		100			0,1	0,15	
Biegeradius R=15mm [bending radius R=15mm]		2			0,1	0,3	
Biegeradius R=7,5mm [bending radius R=7.5mm]		2			0,2	0,5	
Mechanische Eigenschaften [mechanical characteristics]							
Numerische Apertur [numerical aperture]		0,200 ± 0,015					
Kerndurchmesser [µm] [core diameter [µm]]		50,0 ± 2,5					
Maximale Unrundheit des Kerns [%] [maximum core non-circularity [%]]		< 5					
Glasmanteldurchmesser [µm] [cladding diameter [µm]]		125,0 ± 1,0					
Maximale Unrundheit des Glasmantels [%] [maximum cladding non-circularity [%]]		< 1					
Maximale Kern-/Mantel-Konzentrität [µm] [maximum cladding/core concentricity error [µm]]		< 1.5					
Max. Coating-Konzentritätsabweichung [µm] [max. coating concentricity error [µm]]		< 10					
Coating [µm] [coating [µm]]		245 ±10					

Eigenschaften – Linklängen <i>[characteristics – link length]</i>			
IEEE 802.3 Serie <i>[IEEE 802.3 series]</i>	Wellenlänge [nm] <i>[wave length [nm]]</i>	Linklänge Produkt [m] <i>[link length product [m]]</i>	Linklänge nach Norm [m] <i>[link length acc. to standard [m]]</i>
1000 Base-SX	850	1040	800
1000 Base-LX	1300	600	n.a.
10 GBase-SX	850	550	400
10 GBase-LX	1310	300	n.a.

Thermische Eigenschaften - Kabel *[thermal characteristics - cable]*

Betriebstemperatur <i>[operation temperature]</i>	-5°C // +70°C
Lagertemperatur <i>[storage temperature]</i>	-25°C // +70°C

Mechanische Eigenschaften – Kabel *[mechanical characteristics - cable]*

Zugfestigkeit [N] <i>[tensile performance [N]]</i>	800	
Querdruckstabilität [N/100mm] <i>[crush resistance [N/100mm]]</i>	500	
Schlag <i>[impact]</i>	nach <i>[acc. to]</i>	n.a.
Wiederholte Biegung <i>[repeated bending]</i>	nach <i>[acc. to]</i>	n.a.
Torsion <i>[torsion]</i>	nach <i>[acc. to]</i>	n.a.
Kabelbiegung <i>[bend]</i>	nach <i>[acc. to]</i>	n.a.
Längswasserdichtigkeit <i>[water penetration]</i>	nach <i>[acc. to]</i>	n.a.

Normen *[standards]*

UV Beständigkeit <i>[UV resistance]</i>	n.a.		
Brandklasse <i>[fire classification]</i>	nach <i>[acc. to]</i>	Dca-s2-d2-a2	EN 50575 / EN 50399
Halogenfreiheit / Korrosivität <i>[zero halogen, no corrosive gases]</i>	nach <i>[acc. to]</i>	IEC 60754-1	
Flammwidrigkeit <i>[flame propagation]</i>	nach <i>[acc. to]</i>	IEC 60332-1-2, IEC 60332-3-22 Cat. A	
Brandfortleitung <i>[flame spread]</i>	nach <i>[acc. to]</i>	IEC 60332	
Bedruckung <i>[printing]</i>	nach <i>[acc. to]</i>	LEONI – “Product type” – IV(ZN)H – Number of fibers – CPR Class – DoP Number – Prod. Batch”	

Kabelversionen *[cable versions]*

Eigenschaft <i>[characteristics]</i>	Anzahl Fasern <i>[QTY fibres]</i>	Farbe <i>[colour]</i>	Fasertyp <i>[fibre type]</i>	Mantel <i>[jacket]</i> Ø [mm]	Gewicht <i>[weight]</i> [kg/km]	Biegeradius <i>[bending radius]</i> [mm]	Zugkraft <i>[tensile load]</i> [N]	Querdruck, dauernd <i>[crush resistance, continuous]</i> [N]	Querdruck, kurzzeitig <i>[crush resistance, short term]</i> [N]	Brandlast <i>[fire load]</i> [kWh/m]
Werte <i>[values]</i>	12	erikaviolett <i>[heather violet]</i>	G50/125 OM4	7.0	38	70	800	500	n.a.	0.150

Lieferform A (einseitig vorkonfektioniert)
[delivery type A (single sided terminated)]

Lieferform bis 50m // ab 50m [type of delivery up to 50m // from 50m on]	als Kabelring // auf Trommel [as cable ring // on drum]
Gewicht (exemplarisch 1m Trunk) [kg] [weight (exemplary 1m trunk) [kg]]	0,365
Gewicht Mehrmeter [kg] [weight additional meter [kg]]	0,038

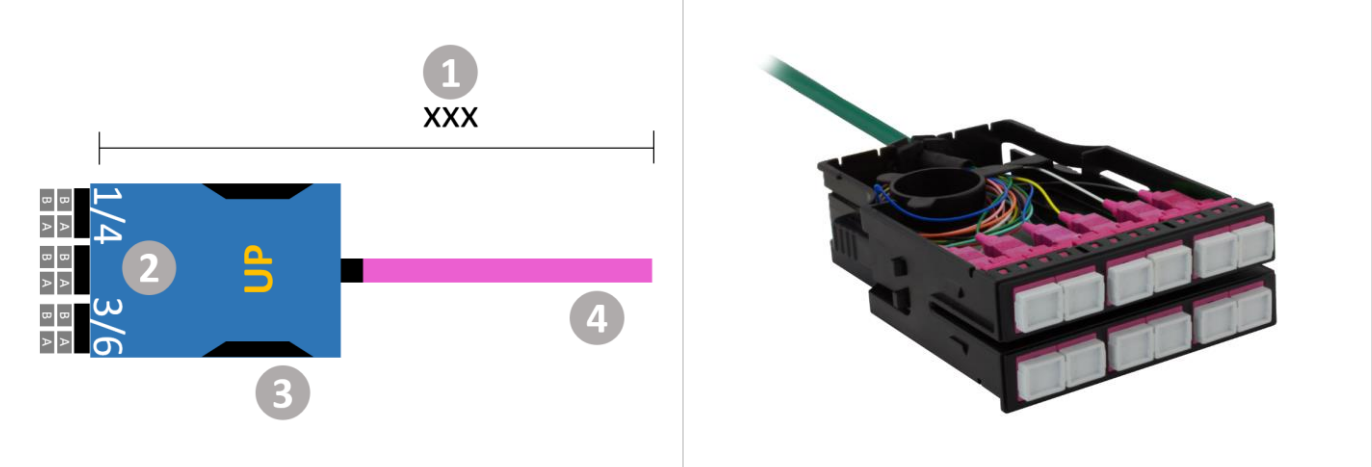

1	Gesamtlänge in Decimeter [total length in decimeter]	2	Kassettengehäuse [cassette housing]
3	Entriegelungslasche [release lug]	4	Multifaserkabel [multifibre cable]

Farbcode nach [colour code acc. to]	1	2	3	4	5	6	7	8	9	10	11	12
		IEC 60304										

Optische Eigenschaften Stecker [optical characteristics connector]			
Qualitätsstufe [quality type]	HS - High Standard	GB - Grade B	GC - Grade C
Hersteller / Marke des Steckers [manufacturer / brand of connector]	Huber & Suhner [Huber & Suhner]	n.a.	n.a.
Farbe Stecker [colour connector]	Beige [beige]	n.a.	n.a.
Farbe Knickschutz [colour boot]	Schwarz [black]	n.a.	n.a.
IL@97% [db]: // RL [db]: IL (typical) [db]: // RL (typical) [db]: IEC 61300-3-34 / IEC 61300-3-6	≤ 0,25 ≥ 35 ≤ 0,12 ≥ 45 GRADE B/3	n.a.	n.a.

Lieferform B (spleißfertig)
[delivery type B (ready to splice)]

Lieferform [type of delivery]	Pappkarton [carton box]
Gewicht [kg] [weight [kg]]	0,3

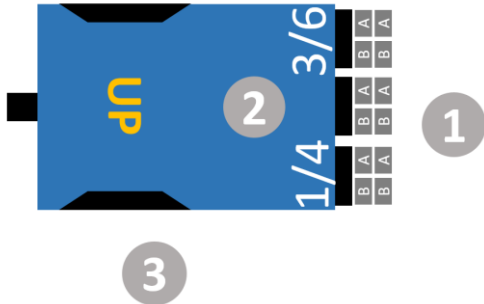

1	Kassette - Spleißversion [cassette - splice version]	2	Kassettengehäuse [cassette housing]
3	Entriegelungslasche [release lug]	4	n.a.

Farbcode nach [colour code acc. to]	1 2 3 4 5 6 7 8 9 10 11 12
	 IEC 60304

Optische Eigenschaften Pigtail [optical characteristics pigtail]			
Qualitätsstufe [quality type]	HS - High Standard	GB - Grade B	GC - Grade C
Hersteller / Marke des Steckers [manufacturer / brand of connector]	Huber & Suhner [Huber & Suhner]	n.a.	n.a.
Farbe Stecker [colour connector]	Beige [beige]	n.a.	n.a.
Farbe Knickschutz [colour boot]	Schwarz [black]	n.a.	n.a.
IL@97% [db]: RL [db]:	≤ 0,25 ≥ 35	n.a.	n.a.
Länge der Faser des Pigtails [m] [length of fibre of the pigtail [m]]	0,5		

Bestellangaben – Lieferform A

[ordering information – delivery type A]

Artikelnummer [part no.]	Beschreibung [description]
4677423-A-5-ES-XXX	CAS-PRE-ES - RZ-Trunkkabel (Dca) - 1x Modulkassette 6xSCdx OM4 - erikaviolett - Kabeltyp: LE - Länge: XXm (offenes Ende) [CAS-PRE-ES - DC-Trunk Cable (Dca) - 1x modular cassette 6xSCdx OM4 - heather violet - cable type: LE - length: XXm (open end)]
	XXX – Längenangabe in Dezimeter // 010 ± 1,00 Meter [XXX – length information in decimeter // 010 ± 1,00 meter]

Bestellangaben – Lieferform B

[ordering information – delivery type B]

Artikelnummer [part no.]	Beschreibung [description]
4677433-C-HS	CAS-SPL - RZ-Modulkassette 6xSCdx OM4 - erikaviolett - 1x Spleiß Equipment (SE-HS-SP-CR) [CAS-SPL - DC-Modular Cassette 6xSCdx OM4 - heather violet - 1x splice equipment (SE-HS-SP-CR)]
4677433-H-HS	CAS-SPL - RZ-Modulkassette 6xSCdx OM4 - erikaviolett - 1x Spleiß Equipment (SE-HS-SP-HS) [CAS-SPL - DC-Modular Cassette 6xSCdx OM4 - heather violet - 1x splice equipment (SE-HS-SP-HS)]
	<p>Legende: [legend]</p> <p>SE – Spleißequipment, dabei: HS – High Standard (Markenstecker) GB – Grade B GC – Grade C</p> <p>SP – Spleißprotektor: CR – Crimp Version HS – Heatshrink Version</p> <p>[SE – splice equipment, with: HS – High Standard (brand connector) GB – Grade B GC – Grade C</p> <p>SP – splice protector: CR – crimp version HS – heat shrink version]</p>

Bestellangaben - Zubehör

[ordering information - accessories]

Artikelnummer [part no.]	Beschreibung [description]
4677270	Verteilerfeldrahmen (leer) zur Aufnahme von 8x Modulkassetten inkl. Kabelmanagementbügel [Patch panel chassis (empty) for mounting of 8x modular cassettes incl. cable management]
4677279	Luftabschlussblende zur Vermeidung unkontrollierter Luftzirkulation für modulares Verteilerfeld [Blanking plate for stopping uncontrolled air circulation for modular patch panel]