

Verbindungstechnik – LWL
[Network Connectivity – FO]

LWL-Einschubmodul für BGTR – OS2 [FO plug-in module for SR – OS2]

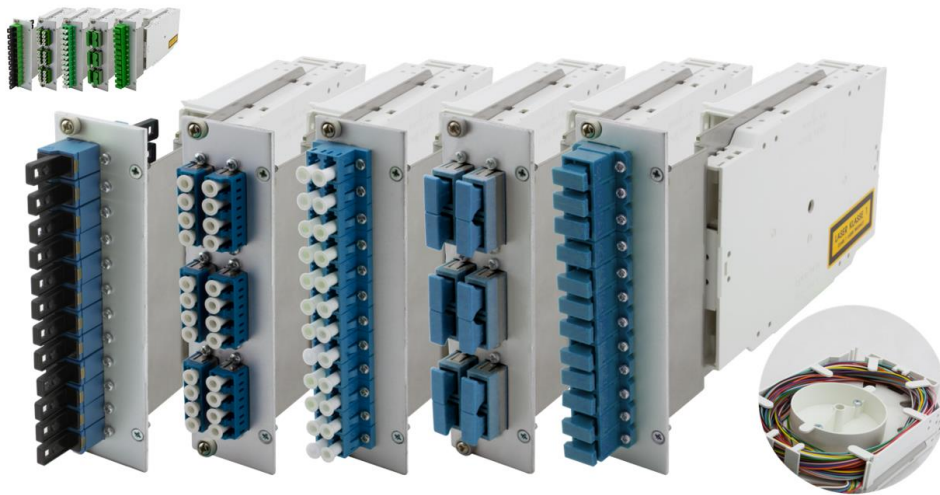

Die TKM LWL-Einschubmodule für Baugruppenträger (BGTR) sind direkt geeignet für die Verwendung in Glasfasernetzen. Sie können komplett vorkonfektioniert oder als Leerversion bestellt werden. Die Einschubmodule sind für alle gängigen Steckertypen verfügbar und sind designed mit den folgenden Funktionen:

- Baugruppenträgereinschub spleißfertig (SRRS): Spleißequipment und Spleißprotector für a) Schrumpfspleißversion oder b) Crimpspleißversion
- optional: Leerversion
- Platzbedarf: 3HE / 7TE
- Gewicht: ca. 450g

[The TKM FO plug-in modules for subracks (SR) are direct applicable to use in FO networks. They can be ordered completely pre-assembled or as empty version. The plug-in modules are available for all current types of connectors and are designed with the following features:

- *subrack plug-in module ready to splice (SRRS): splice equipment and splice protector a) heat shrink version or b) crimp version*
- *optional: empty version*
- *space required: 3U / 7HP*
- *weight: approx. 450g]*

Technische Daten

[technical data]

Kassettenträger [mounting plate]	
Material [material]	Stahlblech [sheet steel]
Oberfläche [surface]	Blank [blank]
Abmaße BxTxH [dimensions WxDxH]	siehe Zeichnung [see drawing]

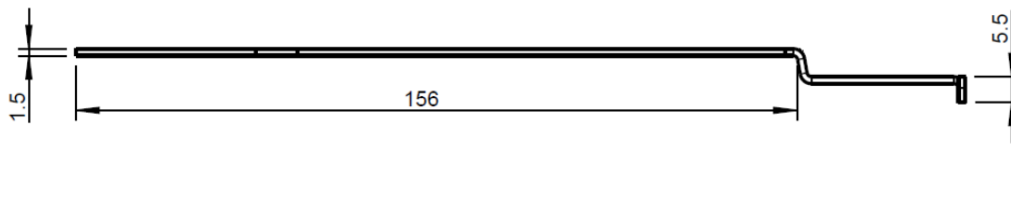
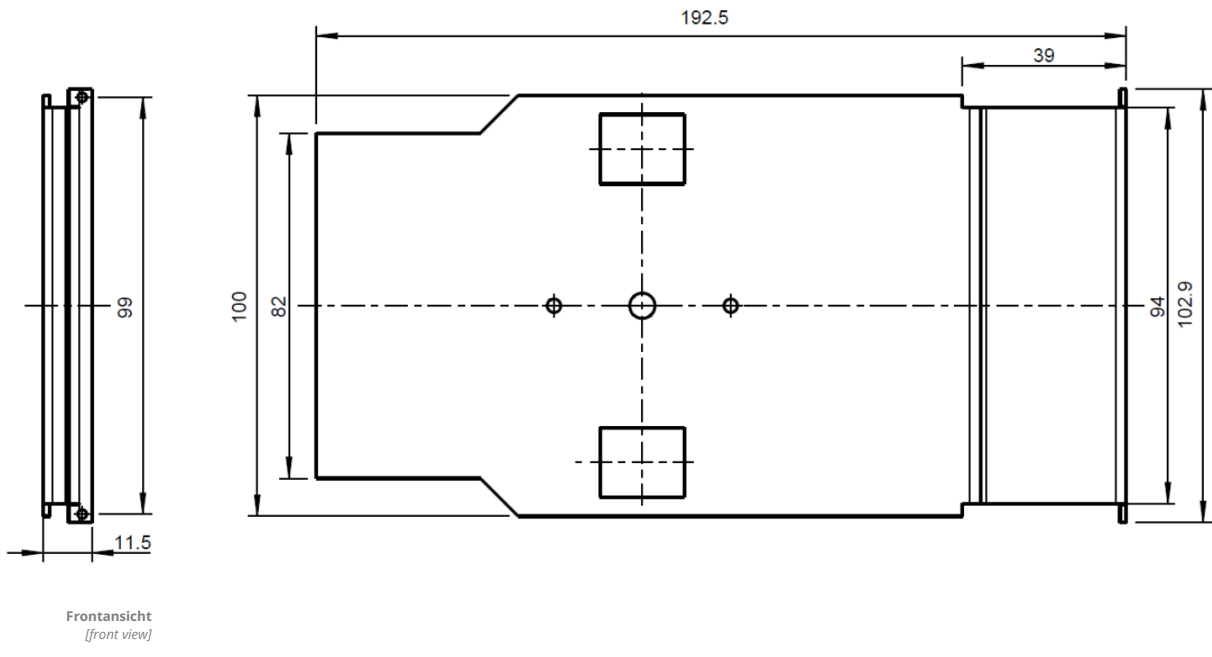

Frontplatte LCdx/SCsx Footprint [front plate LCdx/SCsx footprint]	
Material [material]	Aluminium [aluminium]
Oberfläche [surface]	Eloxal natur [anodized]
Abmaße BxTxH [dimensions WxDxH]	siehe Zeichnung [see drawing]
Breite in TE (Teilungseinheit) [width in HP (horizontal pitch)]	7
Höhe in HE [height in U]	3
Kapazität [capacity]	bis zu 12x LCdx/SCsx Kupplungen [up to 12x LCdx/SCsx adapters]
Portnummerierung (optional) [port numbering (optional)]	1 – 12
Nummerierungsstreifen [numbering strip]	selbstklebender Streifen mit transparenter Abdeckung (in blau in der Zeichnung angedeutet) [adhesive strip with transparent cover (in blue indicated in the drawing)]
Abmaße LxBxT [dimensions LxWxH]	125 x 9,5 x 3,5 mm

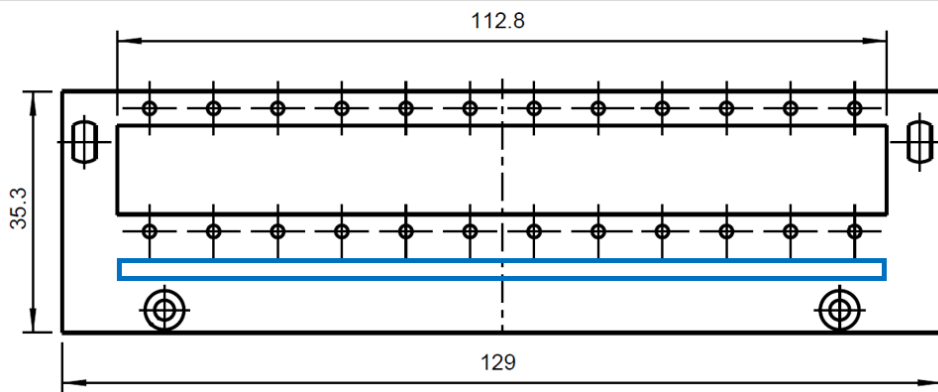

Frontplatte
[front plate]

LWL Kupplung: [FO adapter:]	
Version [version]	LC DX // SC SX // E2000™ (LSH) SX
Material Gehäuse [material body]	Polycarbonat UL 94V0 [polycarbonate UL 94V0]
Farbe Gehäuse [colour body]	blau – ähnlich RAL5019 // grün – ähnlich RAL6018 [blue – similar to RAL 5019 // green – similar to RAL 6018]
Ferrulentyp [type of sleeve]	Keramik [ceramic]
Staubschutz [dust protection]	Inkl. Staubschutzkappe [incl. dust cap]

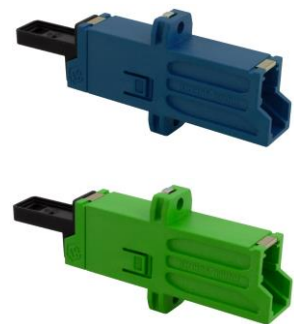
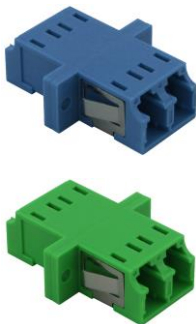

*exemplarische Abbildung
[exemplary picture]

Frontplatte SCdx/LCquad Footprint [front plate SCdx/LCquad footprint]	
Material [material]	Aluminium [aluminium]
Oberfläche [surface]	Eloxal natur [anodized]
Abmaße BxTxH [dimensions WxDxH]	siehe Zeichnung [see drawing]
Breite in TE (Teilungseinheit) [width in HP (horizontal pitch)]	7
Höhe in HE [hight in U]	3
Kapazität [capacity]	bis zu 6x SCdx/LCquad Kupplungen [up to 6x SCdx/LCquad adapters]
Portnummerierung (optional) [port numbering (optional)]	1 – 6
Nummerierungsstreifen [numbering strip]	selbstklebender Streifen mit transparenter Abdeckung (in blau in der Zeichnung angedeutet) [adhesive strip with transparent cover (in blue indicated in the drawing)]
Abmaße LxBxT [dimensions LxWxH]	125 x 9,5 x 3,5 mm

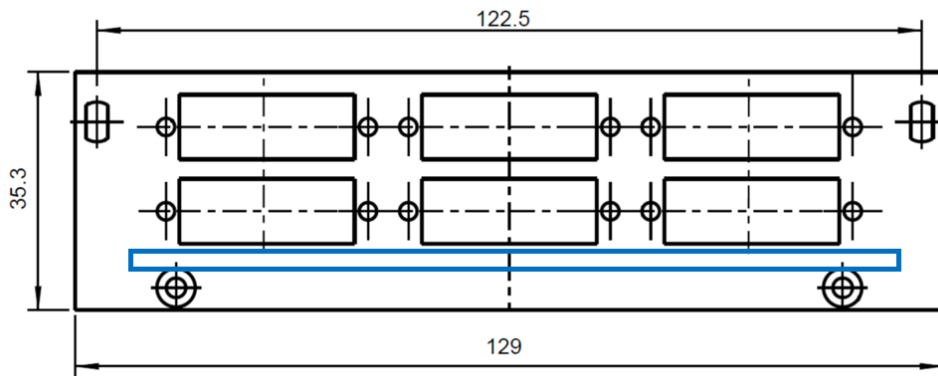

Frontplatte
[front plate]

LWL Kupplung [FO adapter]	
Version [version]	SC DX // LC QUAD
Material Gehäuse [material body]	Polycarbonat UL 94V0 [polycarbonate UL 94V0]
Farbe Gehäuse [colour body]	blau – ähnlich RAL5019 // grün – ähnlich RAL6018 [blue – similar to RAL 5019 // green – similar to RAL 6018]
Ferrulentyp [type of sleeve]	Keramik [ceramic]
Staubschutz [dust protection]	Inkl. Staubschutzkappe [incl. dust cap]

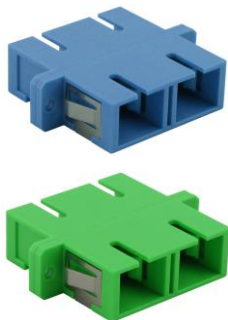

k.A.
[n.a.]



k.A.
[n.a.]

*exemplarische Abbildung
[exemplary picture]



Optional: SE – Spleiß Equipment [optional: SE – splice equipment]

Pigtailset LC [pigtailset LC]				
Steckertyp [types of connector]		LC/PC		
Qualitätsstufe [quality type]	HS – High Standard	GB – Grade B	GC – Grade C	
Hersteller / Marke des Steckers [manufacturer / brand of connector]	Huber & Suhner	n.a.	n.a.	
Farbe Stecker [colour connector]	Schwarz [black]	n.a.	n.a.	
Farbe Knickschutz [colour boot]	Blau [blue]	n.a.	n.a.	
IL@97% [db]: // RL [db]: IL (typical) [db]: // RL (typical) [db]: IEC 61300-3-34 / IEC 61300-3-6	≤ 0,25 ≥ 45 ≤ 0,12 ≥ 55 GRADE B/2	n.a.	n.a.	
				
*exemplarische Abbildung , Produkt kann farblich abweichen [exemplary picture, product may vary in colour]				
Steckertyp [types of connector]		LC/ APC8°		
Qualitätsstufe [quality type]	HS – High Standard	GB – Grade B	GC – Grade C	
Hersteller / Marke des Steckers [manufacturer / brand of connector]	Huber & Suhner	n.a.	n.a.	
Farbe Stecker [colour connector]	Schwarz [black]	n.a.	n.a.	
Farbe Knickschutz [colour boot]	Grün [green]	n.a.	n.a.	
IL@97% [db]: // RL [db]: IL (typical) [db]: // RL (typical) [db]: IEC 61300-3-34 / IEC 61300-3-6	≤ 0,25 ≥ 60 ≤ 0,12 ≥ 70 GRADE B/1	n.a.	n.a.	
				
*exemplarische Abbildung , Produkt kann farblich abweichen [exemplary picture, product may vary in colour]				
Faser [fibre]	1xE9/125 OS2 G.657			
Faserdurchmesser [fibre diameter]	0,9mm			
Material Coating [material of coating]	LSZH			
Farbkodierung Pigtailset [colour code of pigtailset]	gemäß IEC 60304 [acc. to IEC 60304]			
Länge Pigtails gesamt [length of pigtails absolute]	2,50m			
Freie Länge Pigtails ausserhalb Kasette [free length of pigtails outside cassette]	1,50m			
				
*exemplarisch LC Stecker [exemplarily LC connector]				
1	Steckerkörper [connector body]	2	Faser [fibre]	
3	Staubschutzkappe [dust cap]	4	Knickschutz [boot]	

Optional: SE – Spleiß Equipment [optional: SE – splice equipment]

Pigtailset SC [pigtailset SC]				
Steckertyp [types of connector]	SC/PC			
Qualitätsstufe [quality type]	HS – High Standard	GB – Grade B	GC – Grade C	
Hersteller / Marke des Steckers [manufacturer / brand of connector]	Huber & Suhner	n.a.	n.a.	
Farbe Stecker [colour connector]	Blau [blue]	n.a.	n.a.	
Farbe Knickschutz [colour boot]	Schwarz [black]	n.a.	n.a.	
IL@97% [db]: // RL [db]: IL (typical) [db]: // RL (typical) [db]: IEC 61300-3-34 / IEC 61300-3-6	≤ 0,25 ≥ 45 ≤ 0,12 ≥ 55 GRADE B/2	n.a.	n.a.	
		n.a.	n.a.	
		*exemplarische Abbildung, Produkt kann farblich abweichen [exemplary picture, product may vary in colour]		
Steckertyp [types of connector]	SC/APC ^{8°}			
Qualitätsstufe [quality type]	HS – High Standard	GB – Grade B	GC – Grade C	
Hersteller / Marke des Steckers [manufacturer / brand of connector]	Huber & Suhner	n.a.	n.a.	
Farbe Stecker [colour connector]	Grün [green]	n.a.	n.a.	
Farbe Knickschutz [colour boot]	Grün [green]	n.a.	n.a.	
IL@97% [db]: // RL [db]: IL (typical) [db]: // RL (typical) [db]: IEC 61300-3-34 / IEC 61300-3-6	≤ 0,25 ≥ 60 ≤ 0,12 ≥ 70 GRADE B/1	n.a.	n.a.	
		n.a.	n.a.	
		*exemplarische Abbildung, Produkt kann farblich abweichen [exemplary picture, product may vary in colour]		
Faser [fibre]	1xE9/125 OS2 G.657			
Faserdurchmesser [fibre diameter]	0,9mm			
Material Coating [material of coating]	LSZH			
Farbkodierung Pigtailset [colour code of pigtailset]	gemäß IEC 60304 [acc. to IEC 60304]			
Länge Pigtails gesamt [length of pigtails absolute]	2,50m			
Freie Länge Pigtails ausserhalb Kasette [free length of pigtails outside cassette]	1,50m			
				
		*exemplarisch SC Stecker [exemplarily SC connector]		
1	Steckerkörper [connector body]	2	Faser [fibre]	
3	Knickschutz [boot]	4	n.a. [n.a.]	

Optional: SE – Spleiß Equipment
[optional: SE – splice equipment]

Pigtailset E2000™ (LSH): [pigtailset E2000™ (LSH):]				
Steckertyp [types of connector]	E2000™ (LSH)/PC			
Qualitätsstufe [quality type]	HS – High Standard		GB – Grade B	GC – Grade C
Hersteller / Marke des Steckers [manufacturer / brand of connector]	Huber & Suhner [Huber & Suhner]		n.a.	n.a.
Farbe Stecker [colour connector]	blau [blue]		n.a.	n.a.
Farbe Knickschutz [colour boot]	blau [blue]		n.a.	n.a.
IL@97% [db]: // RL [db]: IL (typical) [db]: // RL (typical) [db]: IEC 61300-3-34 / IEC 61300-3-6	≤ 0,25 ≥ 45 ≤ 0,12 ≥ 55 GRADE B/2		n.a.	n.a.
			n.a.	n.a.
	*exemplarische Abbildung , Produkt kann farblich abweichen [exemplary picture, product may vary in colour]			
Steckertyp [types of connector]	E2000™ (LSH)/APC8°			
Qualitätsstufe [quality type]	HS – High Standard		GB – Grade B	GC – Grade C
Hersteller / Marke des Steckers [manufacturer / brand of connector]	Huber & Suhner [Huber & Suhner]		n.a.	n.a.
Farbe Stecker [colour connector]	grün [green]		n.a.	n.a.
Farbe Knickschutz [colour boot]	grün [green]		n.a.	n.a.
IL@97% [db]: // RL (mated) [db]: IL (typical) [db]: // RL (typical) [db]: IEC 61300-3-34 / IEC 61300-3-6	≤ 0,25 ≥ 60 ≤ 0,12 ≥ 70 GRADE B/1		n.a.	n.a.
			n.a.	n.a.
	*exemplarische Abbildung , Produkt kann farblich abweichen [exemplary picture, product may vary in colour]			
Faser [fibre]	1xE9/125 OS2 G.657			
Faserdurchmesser [fibre diameter]	0,9mm			
Material Coating [material of coating]	LSZH			
Farbkodierung Pigtailset [colour code of pigtailset]	gemäß IEC 60304 [acc. to IEC 60304]			
Länge Pigtails gesamt [length of pigtails absolute]	2,50m			
Freie Länge Pigtails ausserhalb Kasette [free length of pigtails outside cassette]	1,50m			
				
	*exemplarisch Stecker [exemplarily connector]			
1	Steckerkörper [connector body]	2	Faser [fibre]	
3	Staubschutzkappe [dust cap]	4	Knickschutz [boot]	

Spezifikation [specification]	
----------------------------------	--

Spleißkassette [splice cassette]	
Material [material]	Acrylnitril-Butadien-Styrol-Copolymere (ABS)
Aufnahmekapazität [capacity]	je Spleißkassette bis zu 24 Fasern [each splice cassette up to 24 fibres]
Gewicht [weight]	30g

Spleißkassettendeckel [splice cassette top cover]	
Material [material]	Acrylnitril-Butadien-Styrol-Copolymere (ABS)
Beschriftung [labelling]	mit Laser-Hinweisschild und Farbcode versehen [signed with laser indicating label and colour code]
Gewicht [weight]	20g

Spleißhalter [splice holder]	
Material [material]	Acrylnitril-Butadien-Styrol-Copolymere (ABS)
Kapazität Version Crimp [capacity version crimp]	12 Positionen für Spleißprotector Crimp [12 positions for splice protector crimp]
Kapazität Version Schrumpf [capacity version heat shrink]	6 Positionen für Spleißprotector Schrumpf [6 positions for splice protector heat shrink]

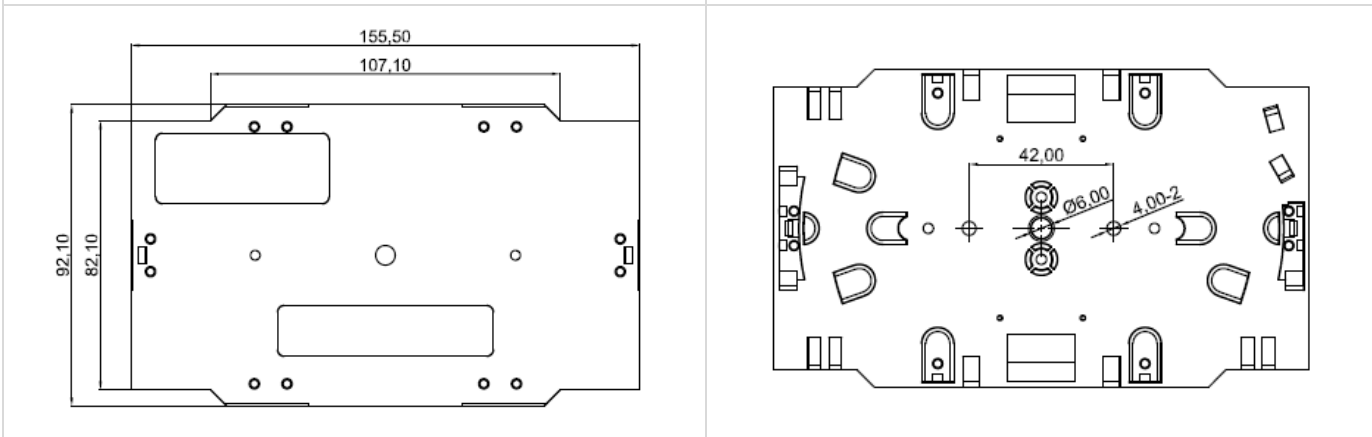
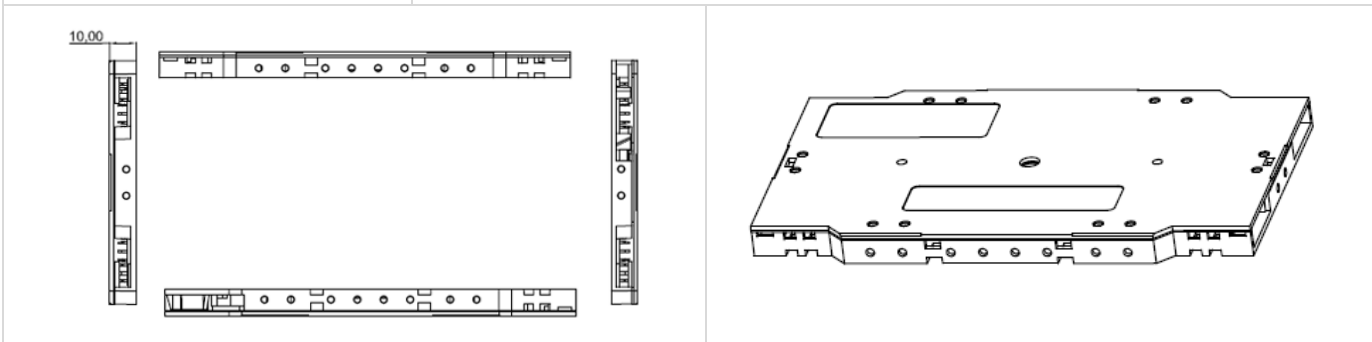

Spezifikation [specification]	
----------------------------------	--

Überlängenkassette [overlength cassette]	
---	--

Material [material]	Acrylnitril-Butadien-Styrol-Copolymere (ABS)
------------------------	--



Abmaße BxTxH [dimensions WxDxH]	siehe Skizze [see drawing]
------------------------------------	-------------------------------

Überlängenkassettendeckel [overlength cassette top cover]	
--	--

Material [material]	Acrylnitril-Butadien-Styrol-Copolymere (ABS)
------------------------	--

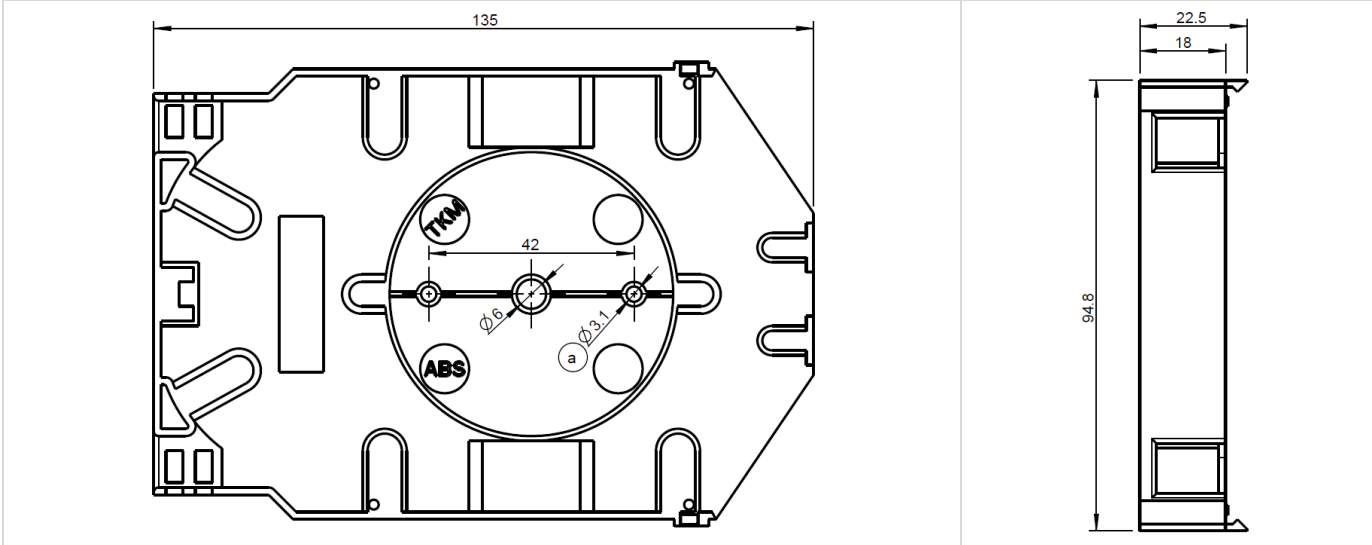
Abmaße BxTxH [dimensions WxDxH]	Passend zur Kassette, Zeichnung ohne Deckel abgebildet [appropriate to cassette, drawing without cover]
------------------------------------	--

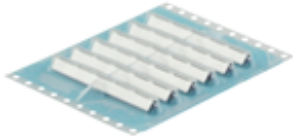
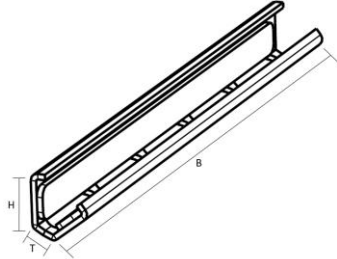

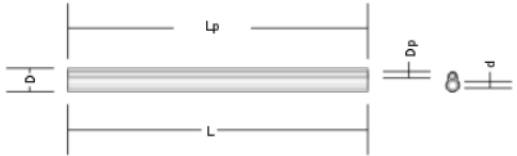
Spleißprotector Crimp <i>[splice protector crimp]</i>	
Abmaße [BxHxT] <i>[dimensions [WxHxD]]</i>	30x3x1,2 mm
Gewicht <i>[weight]</i>	0,3g
Typ Spleißprotector Crimp <i>[type of splice protector]</i>	TKM SSE - 4780015
zugelassen nach <i>[approved for]</i>	TS 0338/96 - Deutsche Telekom
	
*exemplarische Abbildung <i>[exemplary picture]</i>	
Spleißprotector Schrumpf <i>[splice protector heat shrink]</i>	
Abmaße [LxD] <i>[dimensions [LxD]]</i>	40x2,5mm
Gewicht <i>[weight]</i>	0,4g
Typ Spleißprotector Schrumpf <i>[type of splice heat shrink]</i>	TKM - 4780033
	
*exemplarische Abbildung <i>[exemplary picture]</i>	

Bestellangaben [ordering information]

Artikelnummer [part no.]	Beschreibung [description]
Typ Einschubmodul: LCdx – Ausstattung: mit Spleiß Equipment (HS) und Spleißprotector (CR / HS) [type of plug-in module: LCdx – equipment: with splice equipment (HS) and splice protector (CR / HS)]	
4707EC-12L2PC-HSC-OS2	LWL-Einschubmodul für BGTR - OS2-PC – Typ: Eurocard 3HE/7TE – Kupplungen: 12x LCdx – Bestückung: SE-HS-SP-CR [FO plug-in module for SR - OS2-PC – type: Eurocard 3U/7HP – adapters: 12x LCdx – equipped with: SE-HS-SP-CR]
4707EC-12L2A8-HSC-OS2	LWL-Einschubmodul für BGTR - OS2-APC8 – Typ: Eurocard 3HE/7TE – Kupplungen: 12x LCdx – Bestückung: SE-HS-SP-CR [FO plug-in module for SR - OS2-APC8 – type: Eurocard 3U/7HP – adapters: 12x LCdx – equipped with: SE-HS-SP-CR]
Typ Einschubmodul: LCquad – Ausstattung: mit Spleiß Equipment (HS) und Spleißprotector (CR / HS) [type of plug-in module: LCquad – equipment: with splice equipment (HS) and splice protector (CR / HS)]	
4707EC-06L4PC-HSC-OS2	LWL-Einschubmodul für BGTR - OS2-PC – Typ: Eurocard 3HE/7TE – Kupplungen: 6x LCquad – Bestückung: SE-HS-SP-CR [FO plug-in module for SR - OS2-PC – type: Eurocard 3U/7HP – adapters: 6x LCquad – equipped with: SE-HS-SP-CR]
4707EC-06L4A8-HSC-OS2	LWL-Einschubmodul für BGTR - OS2-APC8 – Typ: Eurocard 3HE/7TE – Kupplungen: 6x LCquad – Bestückung: SE-HS-SP-CR [FO plug-in module for SR - OS2-APC8 – type: Eurocard 3U/7HP – adapters: 6x LCquad – equipped with: SE-HS-SP-CR]
Typ Einschubmodul: SCsx – Ausstattung: mit Spleiß Equipment (HS) und Spleißprotector (CR / HS) [type of plug-in module: SCsx – equipment: with splice equipment (HS) and splice protector (CR / HS)]	
4707EC-12S1PC-HSC-OS2	LWL-Einschubmodul für BGTR - OS2-PC – Typ: Eurocard 3HE/7TE – Kupplungen: 12x SCsx – Bestückung: SE-HS-SP-CR [FO plug-in module for SR - OS2-PC – type: Eurocard 3U/7HP – adapters: 12x SCsx – equipped with: SE-HS-SP-CR]
4707EC-12S1A8-HSC-OS2	LWL-Einschubmodul für BGTR - OS2-APC8 – Typ: Eurocard 3HE/7TE – Kupplungen: 12x SCsx – Bestückung: SE-HS-SP-CR [FO plug-in module for SR - OS2-APC8 – type: Eurocard 3U/7HP – adapters: 12x SCsx – equipped with: SE-HS-SP-CR]
Typ Einschubmodul: SCdx – Ausstattung: mit Spleiß Equipment (HS) und Spleißprotector (CR / HS) [type of plug-in module: SCdx – equipment: with splice equipment (HS) and splice protector (CR / HS)]	
4707EC-06S2PC-HSC-OS2	LWL-Einschubmodul für BGTR - OS2-PC – Typ: Eurocard 3HE/7TE – Kupplungen: 6x SCdx – Bestückung: SE-HS-SP-CR [FO plug-in module for SR - OS2-PC – type: Eurocard 3U/7HP – adapters: 6x SCdx – equipped with: SE-HS-SP-CR]
4707EC-06S2A8-HSC-OS2	LWL-Einschubmodul für BGTR - OS2-APC8 – Typ: Eurocard 3HE/7TE – Kupplungen: 6x SCdx – Bestückung: SE-HS-SP-CR [FO plug-in module for SR - OS2-APC8 – type: Eurocard 3U/7HP – adapters: 6x SCdx – equipped with: SE-HS-SP-CR]
Typ Einschubmodul: E2000sx – Ausstattung: mit Spleiß Equipment (HS) und Spleißprotector (CR / HS) [type of plug-in module: E2000sx – equipment: with splice equipment (HS) and splice protector (CR / HS)]	
4707EC-12E1PC-HSC-OS2	LWL-Einschubmodul für BGTR - OS2-PC – Typ: Eurocard 3HE/7TE – Kupplungen: 12x E2000sx – Bestückung: SE-HS-SP-CR [FO plug-in module for SR - OS2-PC – type: Eurocard 3U/7HP – adapters: 12x E2000sx – equipped with: SE-HS-SP-CR]
4707EC-12E1A8-HSC-OS2	LWL-Einschubmodul für BGTR - OS2-APC8 – Typ: Eurocard 3HE/7TE – Kupplungen: 12x E2000sx – Bestückung: SE-HS-SP-CR [FO plug-in module for SR - OS2-APC8 – type: Eurocard 3U/7HP – adapters: 12x E2000sx – equipped with: SE-HS-SP-CR]
	<p>Legende: [legend]</p> <p>SE – Spleißequipment, dabei: HS – High Standard (Markenstecker) [SE – splice equipment, with: HS – High Standard (brand connector)</p> <p>SP – Spleißprotector: CR – Crimp Version SP – splice protector: HS – Heatshrink Version CR – crimp version HS – heat shrink version</p>
	<p>Hinweis: [note:]</p> <p>Alle Einschubmodule mit Heat Shrink Spleißprotector (HS) max. mit 12 Fasern [all plug-in module with heat shrink splice protector (HS) max. with 12 fibres]</p> <p>4707EC-03L4XX-XXH-XXX 4707EC-03L4XX-XXH-XXX 4707EC-06L2XX-XXH-XXX 4707EC-06L2XX-XXH-XXX 4707EC-06S2XX-XXH-XXX 4707EC-06S2XX-XXH-XXX 4707EC-12S1XX-XXH-XXX 4707EC-12S1XX-XXH-XXX</p>

Bestellangaben - Zubehör

[ordering information - accessories]

Artikelnummer <i>[part no.]</i>	Beschreibung <i>[description]</i>
01-57-35-0045	Nummerierungsstreifen 8mm – selbstklebend mit transparenter Abdeckung - Abmaße LxBxT ca. 125x9,5x3,5mm <i>[numbering strip 8mm – adhesive with transparent cover - dimensions LxWxH: approx.125x9,5x3,5mm]</i>
	 <p data-bbox="1235 427 1471 470">*exemplarische Abbildung <i>[exemplary picture]</i></p>